

SET-UP SHEET

XRAY X1

RACE	TROFEO FABOWEB 17/5
TRACK	VEDANO AL LAMBRO (MI)

NAME	DAVIDE CARBONE
CITY / COUNTRY	ITALY
CONTACT	informazioni@rcsupermarket.com

DATE	17/05/2015
------	------------

QUALIFYING POSITION	BEST LAPTIME /sec	FINAL POSITION	RACE LENGTH /min
2	18.083	1	5

TRACK	
TRACK SURFACE	<input type="checkbox"/> CARPET <input checked="" type="checkbox"/> ASPHALT
TRACK LAYOUT	<input checked="" type="checkbox"/> TECHNICAL <input type="checkbox"/> MIXED <input type="checkbox"/> FAST
TRACTION	<input type="checkbox"/> LOW <input checked="" type="checkbox"/> MEDIUM <input type="checkbox"/> HIGH

CENTER SHOCK ABSORBER		
2.2	700	0%
SPRING	OIL /cst	REBOUND %

SIDE SHOCK	
OIL /cst	600

FRONT	TIRES	REAR
GRP	TIRES	GRP
Marka	ADDITIVE	Marka
20'	ADDITIVE TIMING	20'
FRONT LEFT	ADDITIVE TREATED AREA	REAR LEFT
FRONT RIGHT		REAR RIGHT

DIFF SETTING	
<input type="checkbox"/>	<input checked="" type="checkbox"/>
LOOSE	TIGHT

GEARING		
35	96	2.74
PINION /T	SPUR GEAR /T	FINAL DRIVE RATIO

ELECTRONICS	
MOTOR	HIROSAKA 40°
SPEEDO	Hobbywing Just Stock - 60% Drag Brake
BATTERIES	LRP

BODY	
X1 ORIGINAL	

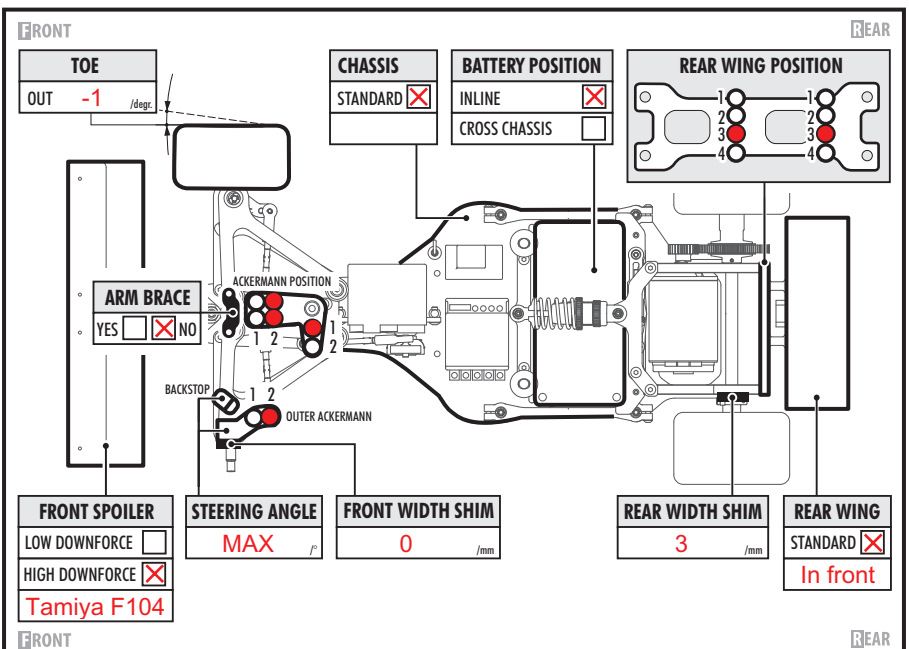
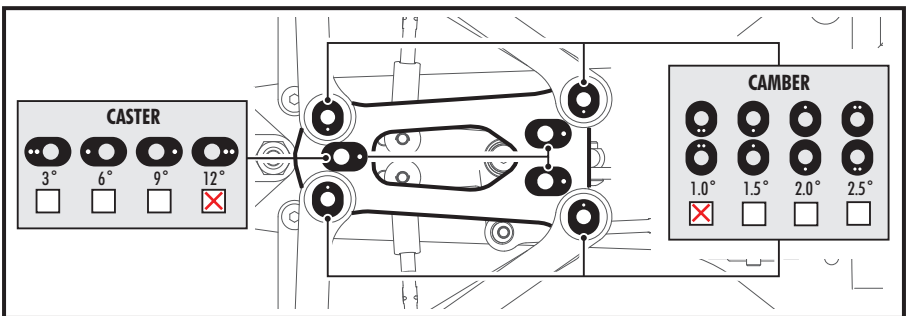
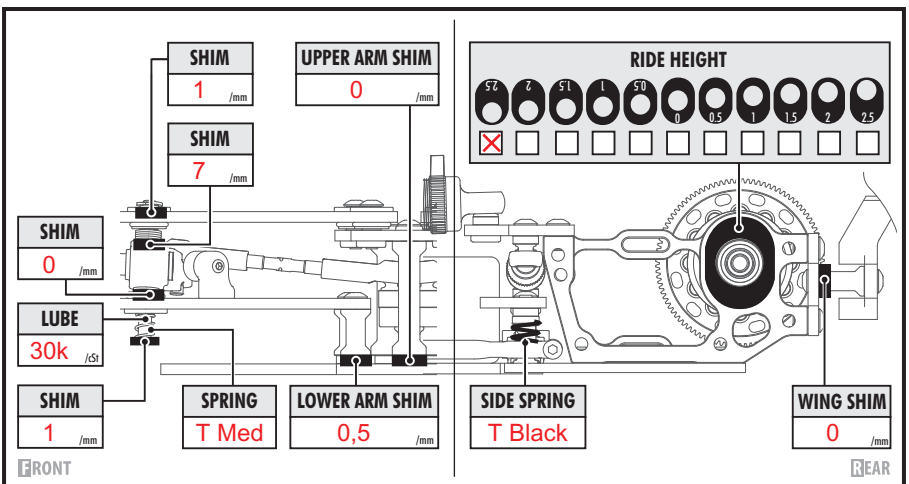
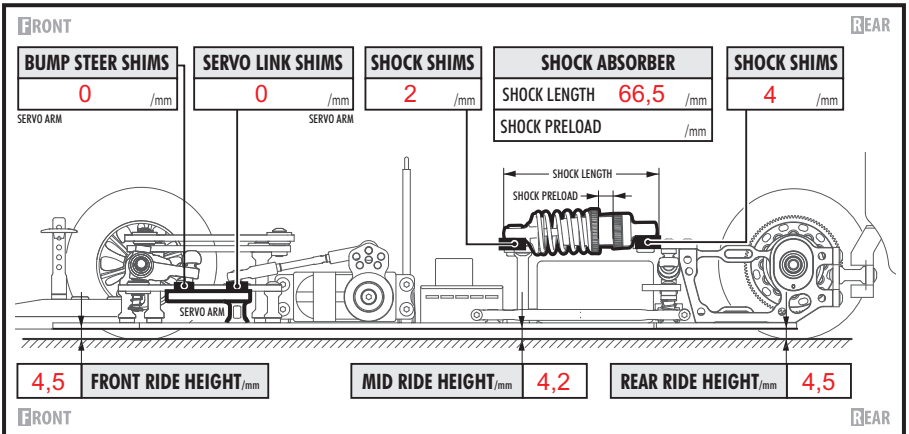

COMMENTS

2mm di spessore sotto l'attacco posteriore del braccetto anteriore superiore (anti dive)
 Il banchino motore è stato rialzato di 2,5mm per avere maggiore rollio (centro di rollio alto).
 Avendo alzato il banchino occorre adeguare le rondelle sotto all'attacco posteriore dell'ammortizzatore centrale e sullo smorzatore.